

Table of contents

Article numbers	page 3
Packing details	page 4
Bill of materials	page 5
Assembly and use	page 6
Dimensions	page 7
Specifications	page 8
Safety & test	page 9



Article numbers

Article number	EAN code
TS1000B 4BXX1	5 708499 117227
TS1000B 7BXX1	5 708499 117180
TS1000B 8BXX1	5 708499 117203

Ordering example

TS	1000	B	7	B	XX1
					Free numbers
				Colour	B = black RAL 9004
			AC Plug and voltage	4 = NZ/AUS, 2-Pin plug, 100-240VAC 7 = EU & UK, 2-Pin plug, 100-240VAC 8 = US, 2-Pin plug, 100-240VAC	
		Configuration	A or B		
		Stroke	1000 = 1000mm		
		Mechanism type	TS = TV Stand		



Packing details

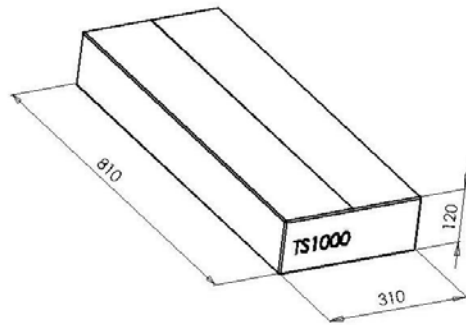

1 pcs.

17,2 kg

0,029 m³

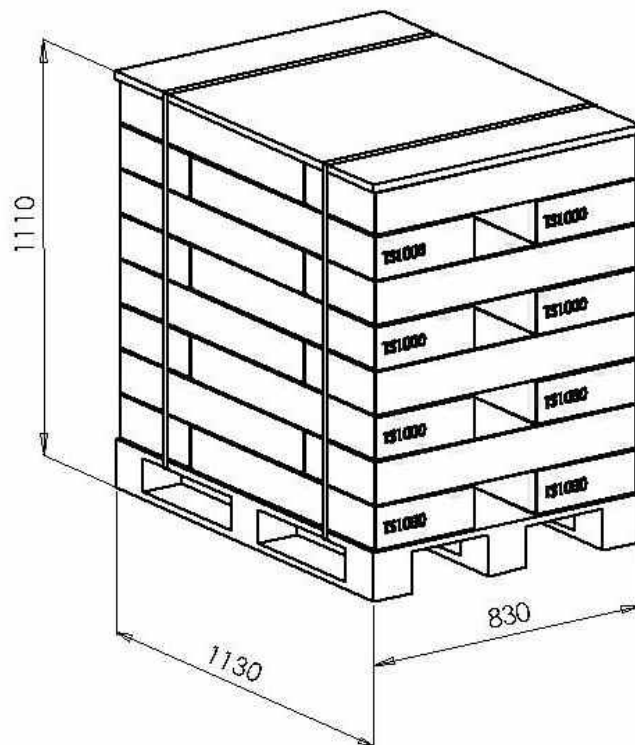

24 pcs.

428 kg

1,041 m³

Bill of material

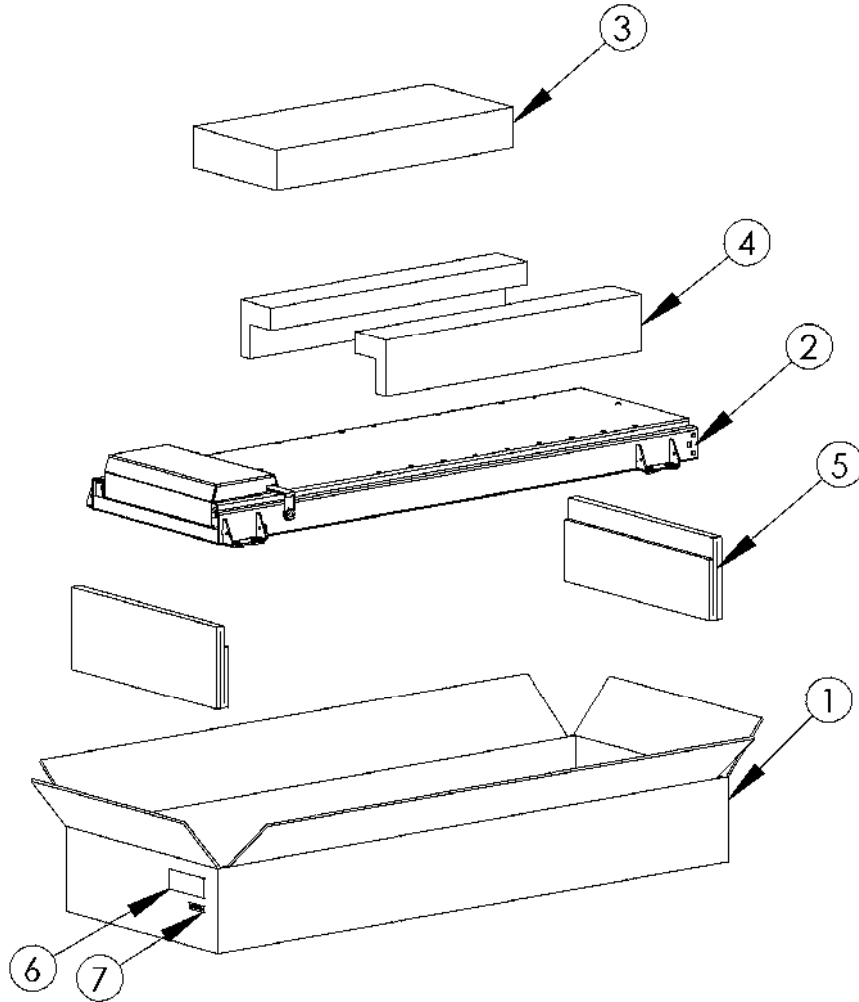

ITEM NO.	QTY	PART NO.	DESCRIPTION
1	1	323360	Cardboard box,
2	1	117340	TS1000B assembly
3	1	117320	B - Power and acc. box packed, EU
4	2	323680	PC block
5	2	313710	Cardboard block
6	1	316960	ID label
7	1	317920	Serial no. Label

Assembly and use

The electrical components should be connected after mounting the lift. All wires have DC jacks or multi plugs and since using different types only the correct connection can be made.

All products come with an instruction manual.

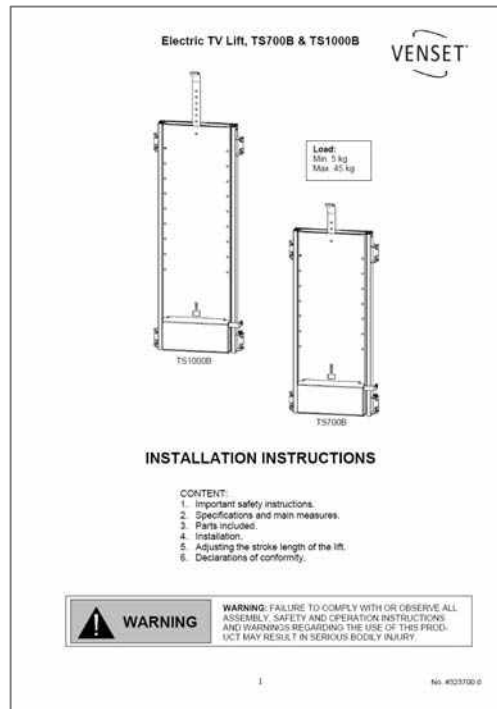

The mechanism can now be operated up and down using the supplied rocker switch. Push "UP" and the lift will expand. Pushing "DOWN" and the lift will contract.

Dimensions [mm]

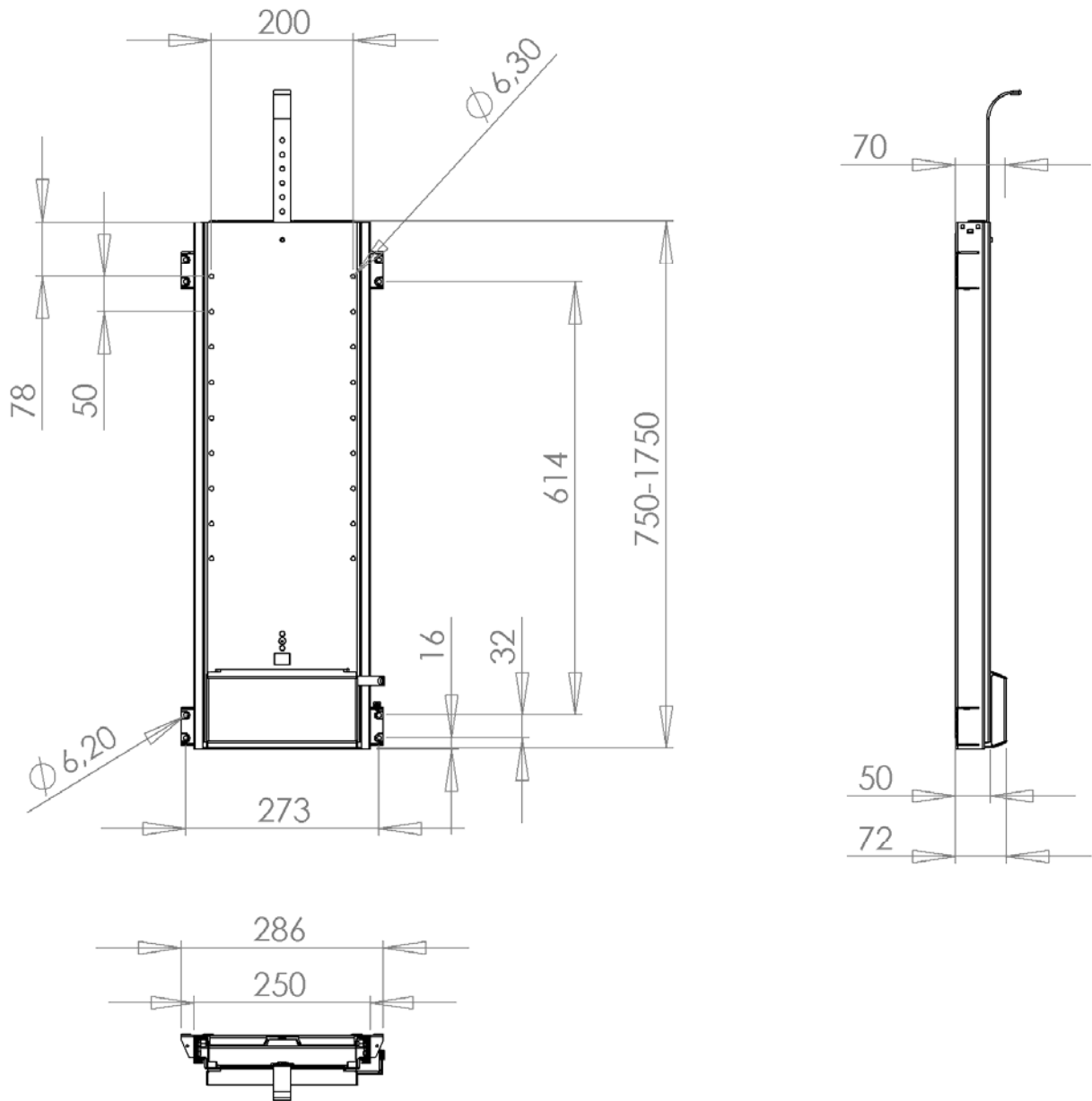

Specifications

Mechanism

Stroke	1000mm
Max. working loads:	45 kg (by standard installation) 29 kg (when lift is mounted upside down) 50 kg peak load
Duty cycle:	10% by 50% of working load or max 2 min. continuously
Speed	28 mm/sec (unloaded)
VESA	200x200 - 200x100

Component

Metal sheet parts:	St 37-2
Gear parts:	St 70-2
Gear motor:	VENSET brand motor no. 324480
Power supply:	120 W AC Power Transformer Consumption: 60 W (max. 120 Watts); Standby: Max 0,9 Watts
Plastic components:	PEHD, PA6, POM
Surface treatment	Visible metal parts powder coated in black colour, RAL 9004 Non visible metal parts are surface treated (e.g. zinc plated)
Operating system:	Rocker switch (RF remote system is optional)

Safety & test

Overensstemmelseserklæring

Declaration of conformity

Fabrikant (navn og adresse): VENSET A/S, Nygade 63, DK-6900 Skjern, Denmark
Manufacturer (name and address):

Erklærer hermed, at følgende produkt:
Hereby certify that the following product:

Benævnelse, mærke, type:
Description, ID/mark, type:

Elektrisk TV-lift, TS700 & TS1000 series
Electric TV-lift, TS700 & TS1000 series

Evt. serienr.:
Serial No. if any:

Alle efter serie nr. V-00067
All after serial No. V-00067

Er fremstillet i overensstemmelse med Europa-Parlamentets og Rådets Direktiv af 15. december 2004 om indbyrdes tilnærmelse af medlemsstaternes lovgivning om elektromagnetiske kompatibilitet (2004/108/EF) ifølge standarderne DS/EN 55014-1:2007, DS/EN 55014-2:1997, DS/EN 61000-3-2:2006, EN 61000-3-3:2008
Complies with the EMC directive 2004/108/EC according to the standards DS/EN 55014-1:2007, DS/EN 55014-2:1997, DS/EN 61000-3-2:2006, EN 61000-3-3:2008

og er fremstillet i overensstemmelse med Europa-Parlamentets og Rådets Direktiv af 12. december 2006 om indbyrdes tilnærmelse af medlemsstaternes lovgivning om elektrisk materiel bestemt til anvendelse inden for visse spændingsgrænser (2006/95/EF) ifølge standarden DS/EN 60335-1:2006
and complies with the DIRECTIVE 2006/95/EC OF THE EUROPEAN PARLIAMENT AND OF THE COUNCIL of 12 December 2006 on the harmonization of the laws of Member States relating to electrical equipment designed for use within certain voltage limits (codified version) according to the standard DS/EN 60335-1:2006

Navn, titel og underskrift af fabrikanten:
Name, title and signature of manufacturer:

28/8-2008

Dato/date

H. Overgaard
Approval Engineer
Underskrift/signature

VENSET
VENSET A/S
Nygade 63 · DK-6900 Skjern
Tel: +45 9735 4611 · Fax: +45 9735 4631



EF – komponenterklæring type "bilag II B"

EEC Declaration of a component "appendix II B"

Fabrikant (navn og adresse):

Manufacturer (name and address):

VENSET A/S, Nygade 63, 6900 Skjern, Denmark

Erklærer hermed, at følgende produkt:

Hereby certify that the following product:

Benævnelse, mærke, type:

Description, ID/mark, type:

Elektrisk TV-lift, TS700 & TS1000 series

Electric TV-lift, TS700 & TS1000 series

Evt. serienr.:

Serial No. if any:

Alle efter serie nr. V-00067

All after serial No. V-00067

Evt. bemyndigede organ og nr.

Notified body if any:

Teknologisk Institut, Århus, Denmark

Evt. EF- typeattest:

EEC-type certificate if any:

Evt. Harmoniserede standarder:

Harmonised standards if any:

Er fremstillet i overensstemmelse med bekendtgørelse nr. 561 af 24. juni 1994, der

gennemfører EUROPA-PARLAMENTETS OG RÅDETS DIREKTIV 98/37/EF

Made according to announcement No. 561 of June 24, 1994 that implements the DIRECTIV 98/37/EF

Ovennævnte produkt må **IKKE** tages i brug, før den maskine, hvori det er indbygget eller hvortil det skal anvendes er erklæret i overensstemmelse med alle relevante bestemmelser.

Above product may **not** be taken into use, before the machine into which it has been built in or to which purpose it must be used for, conform to any relevant regulations.

Navn, titel og underskrift af fabrikanten:

Name, title and signature of manufacturer:

28/8-2009

Dato/date

M. Overgaard
Approval Engineer

Underskrift/signature

VENSET

VENSET A/S
Nygade 63 · DK-6900 Skjern
Tel: +45 9735 4611 · Fax: +45 9735 4631

