

FLIP

The Bouncepad Flip sits elegantly on your counter top, the perfect solution for screen sharing and point of sale applications.

- Weighted base and skilfully engineered hinge makes screen sharing smooth and simple

- Extra security if tethered with one of our reinforced cables

- Triangular base neatly stores power cables

- Can stand alone without being fixed down and withstand vigorous day-to-day usage

- Easily transforms to point of sale by combining with a card reader



PRODUCT DATA SHEET - FLIP (MAXI CASE)

bouncepad®

Case:	Arm:	Mounting:	Packaged weight:	Colour:
Maxi	Flip	Not Applicable	3.27kg	White Black

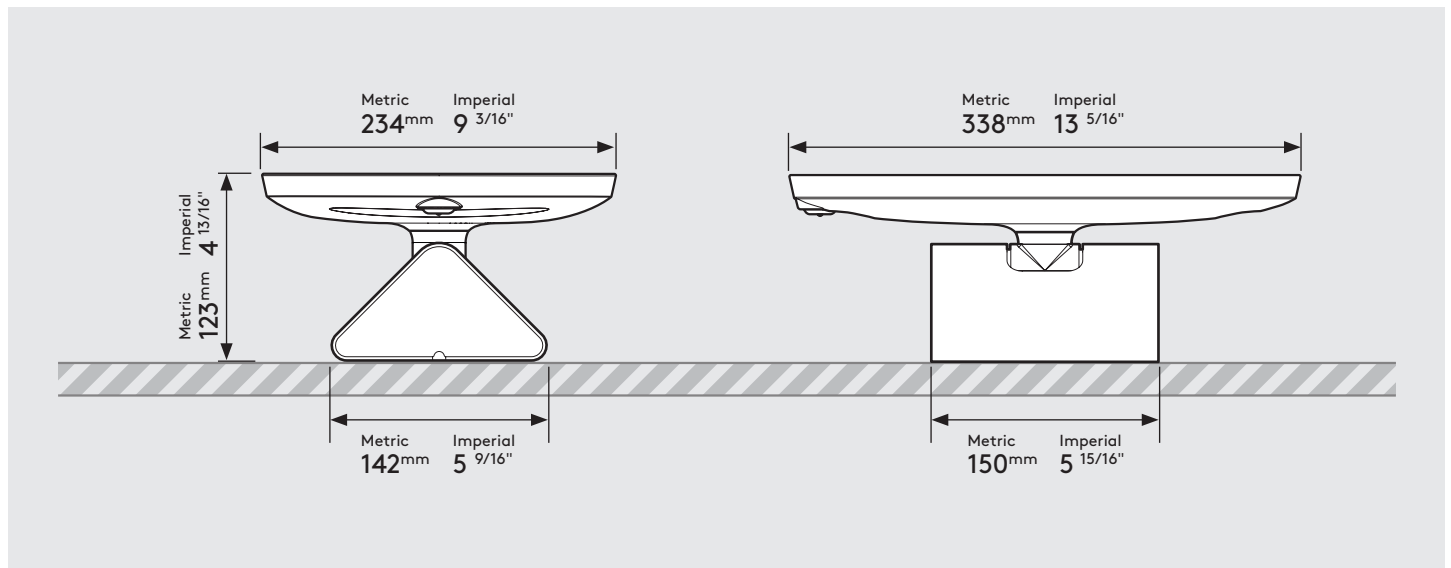

Parts in the Box

