

# COUNTER FLEX

The Bouncepad Counter Flex is designed to protect and secure the tablet whilst offering a full range of movement for ergonomic interaction.



- Freestanding base makes it simple to move around on the countertop

- Provides robust stability without the permanent fixing

- Allows maximum interaction without compromising on comfort or security

- Stalk is made of tough metal alloys once flexed into position the case stays put

- Can be tethered with one of our reinforced cables for extra security

# PRODUCT DATA SHEET - COUNTER FLEX (MAXI CASE)

**bouncepad®**

**Case:** Maxi    **Arm:** Flex    **Mounting:** Freestanding Base    **Packaged weight:** 4.5kg    **Colour:** White  
Black

## Dimensions

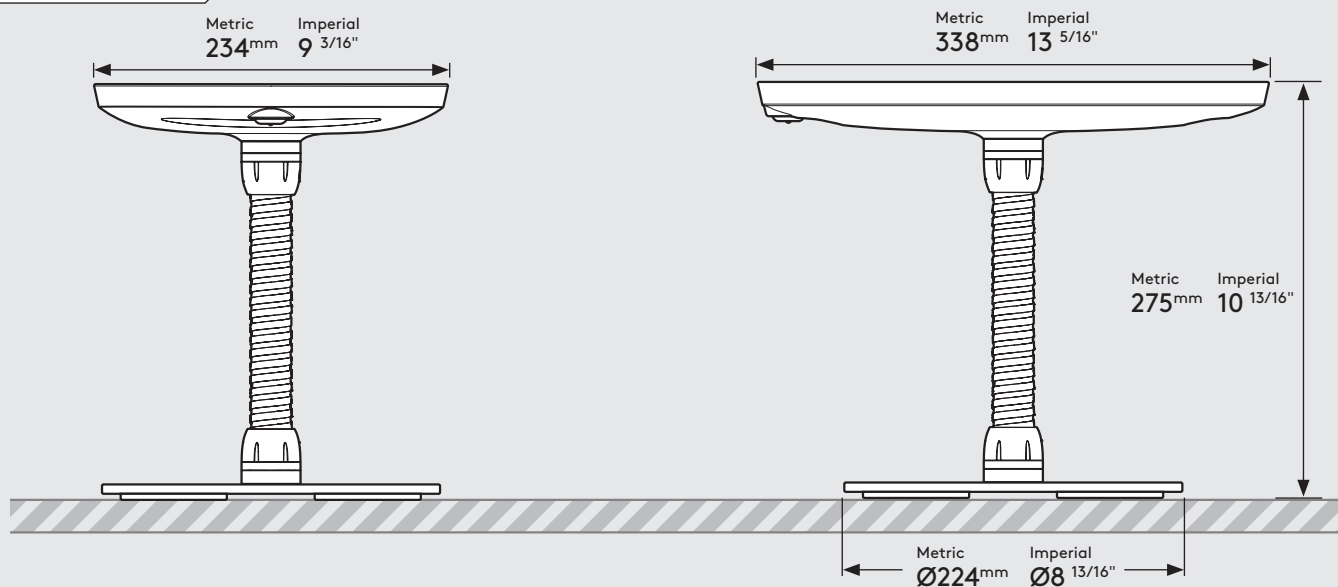

## Parts in the Box

