

SP746PU	SmartMount® Articulating Wall Mount for 32" to 50" Displays
----------------	---

Product Specifications

	DIMENSIONS (W x H x D)	PRODUCT WEIGHT	LOAD CAPACITY	FINISH	AVAILABLE COLORS
SP746PU	19.21" x 16.75" x 3.46"-12.84" (488 x 425 x 88-326mm)	10.36lb (4.70kg)	80lb (36kg)	Scratch resistant fused epoxy	Semi-gloss black

Package Specifications

	PACKAGE SIZE (W x H x D)	PACKAGE SHIP WEIGHT	PACKAGE UPC CODE	PACKAGE CONTENTS	UNITS IN PACKAGE
SP746PU	20.68" x 4.19" x 12.00" (525 x 106 x 305mm)	11.15lb (5.06kg)	735029271918	Wall mount, wall and display installation hardware, installation instructions	1

Accessories **WSP700/WSP701:** Metal Stud Wall Plates for 16"/24" Center Metal Studs

All dimensions = **inch** (mm)

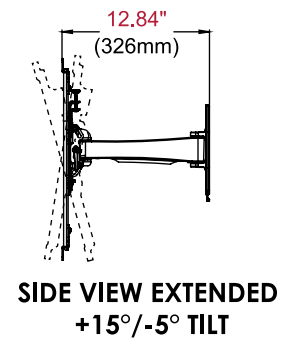
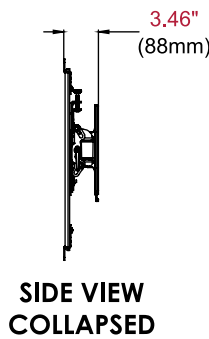
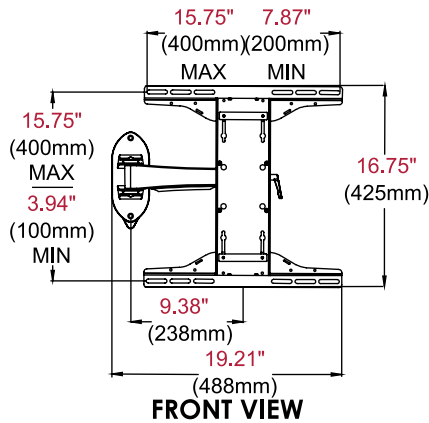
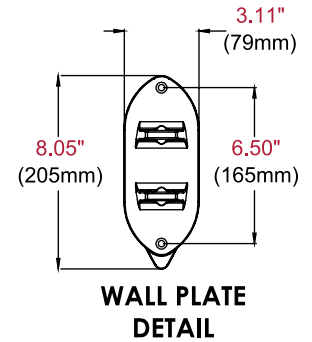

Architect Specifications

The Smartmount® Pivoting Wall Mount shall be a Peerless-AV model SP746PU and shall be located where indicated on the plans. Assembly and installation shall be done according to instructions provided by the manufacturer.

Visit peerless-av.com to see the complete line of AV solutions from Peerless-AV, including outdoor displays, wireless, kiosks, digital audio, display mounts, projector mounts, carts/stands, and a full assortment of accessories.

Peerless-AV
2300 White Oak Circle
Aurora, IL 60502 USA
(800) 865-2112
(630) 375-5100
Fax: (800) 359-6500

Peerless-AV Europe
Unit 3 Watford Interchange
Colonial Way, Watford
Herts, WD24 4WP
United Kingdom
+44 (0) 1923 200100
Fax: +44 (0) 1923 200101

Peerless-AV de México
Ave de las Industrias 413
Parque Industrial Escobedo
Escobedo, N.L.,
Mexico 66050
+52 (81) 8384-8300
Fax: +52 (81) 8384-8360

